



1200 X 1800 MM

GLAZED VITRIFIED TILES

2024

COLLECTION



EXCEPTIONAL SURFACES MULTIFARIOUS APPLICATION POSSIBILITIES

Our tiles are designed for multi-application versatility. From kitchens and bathrooms to living spaces, they seamlessly blend style and function. Elevate your home with the beauty and durability of our ceramic tiles, a perfect choice for various design needs.



APPLICATION AREAS

-  Residential Areas
-  Commercial Areas
-  Hospitals
-  Shops and Malls
-  Hotels and Restaurants
-  Factory





INTRODUCING OUR RESILIENT POLISHED SURFACE

The breadth, eclecticism and charm of a thousand marble effects and the lightness of 9 mm thick hi-tech stoneware come together in I2OXI8OCM.

technical and aesthetic research has perfected the performance of this collection, increasingly matching the beauty of stone with the practicality of large ceramic slabs and enhancing the sensory experience with soft polished feel.



TECHNICAL CHARACTERISTIC



BRACE
YOURSELF FOR
AN EXTRAORDINARY
EXPERIENCE





ALFANZO WHITE



ASPIRE WHITE



ASTON NATURAL



BELGIA WHITE



BRECCIA SPRING



CALACATTA GLACIER



CASA GREY



CASA



DEKTON WHITE



DURATO BEIGE



EBRO NATURAL



FUSION BEIGE



FUSION BIANCO



FUSION GRIS



GENOA BEIGE



LEVIN GREY



LYON MOON



MACAEL WHITE



MACUBA NATURAL



MERADIAN



NUVOLA GREY



ONYX SAFFRON



PARIS BEIGE



RIVIERA GREY



ROYAL STATUARIO



SARRON COLIN



SATURN BROWN



SYBER ASH



SYBER GREY



VEGAS BEIGE

1200X
1800MM | GLOSSY
SURFACE

ALFANSO WHITE - 3 RANDOMS

ENDLESS DESIGN





ALFANSO WHITE
1200X1800MM | GLOSSY FINISH

1200X
1800MM | GLOSSY
SURFACE

ASPIRE WHITE - 3 RANDOMS





ASPIRE WHITE
1200X1800MM | GLOSSY FINISH

1200X
1800MM | GLOSSY
SURFACE

ASTON NATURAL - 3 RANDOMS

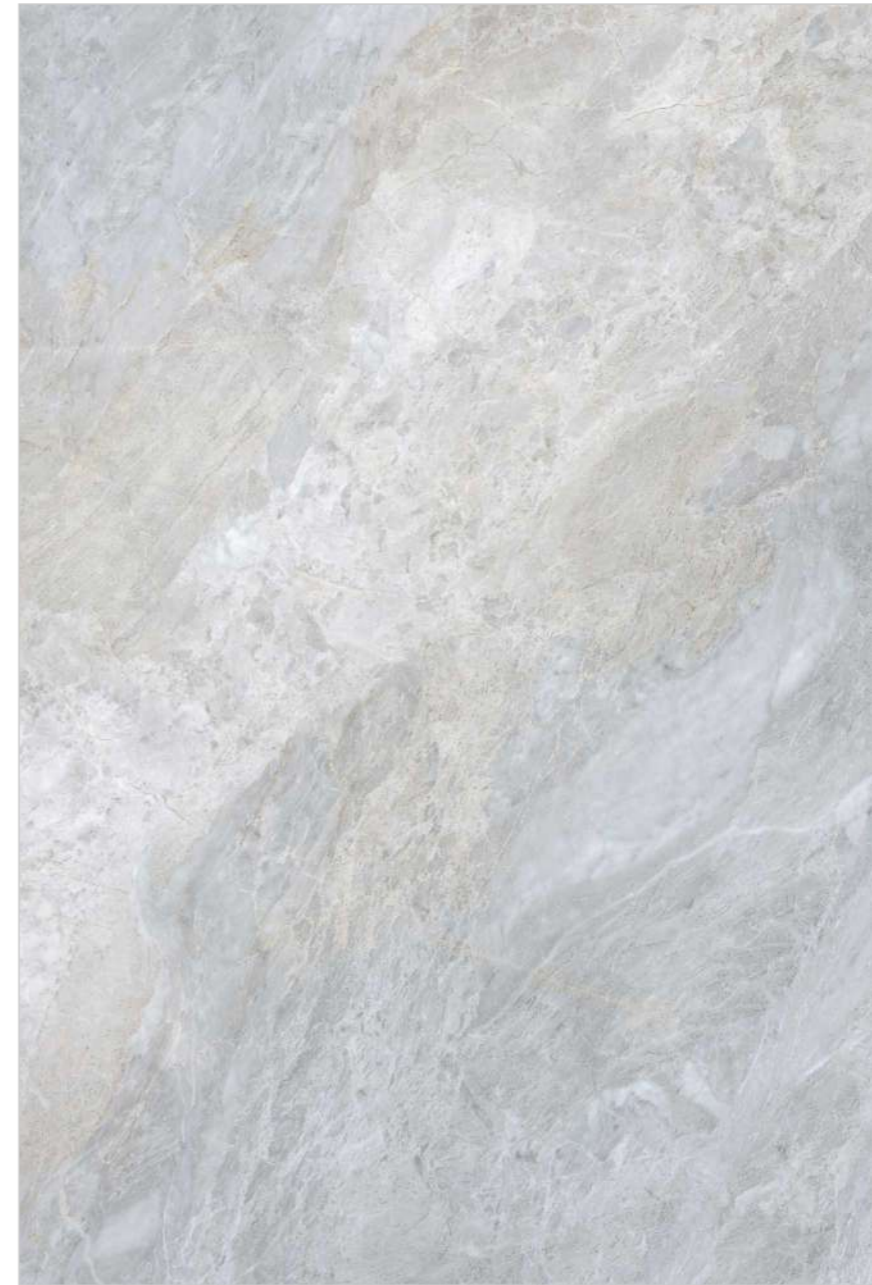



ASTON NATURAL
1200X1800MM | GLOSSY FINISH

1200X
1800MM | GLOSSY
SURFACE

BELGIA WHITE - 3 RANDOMS

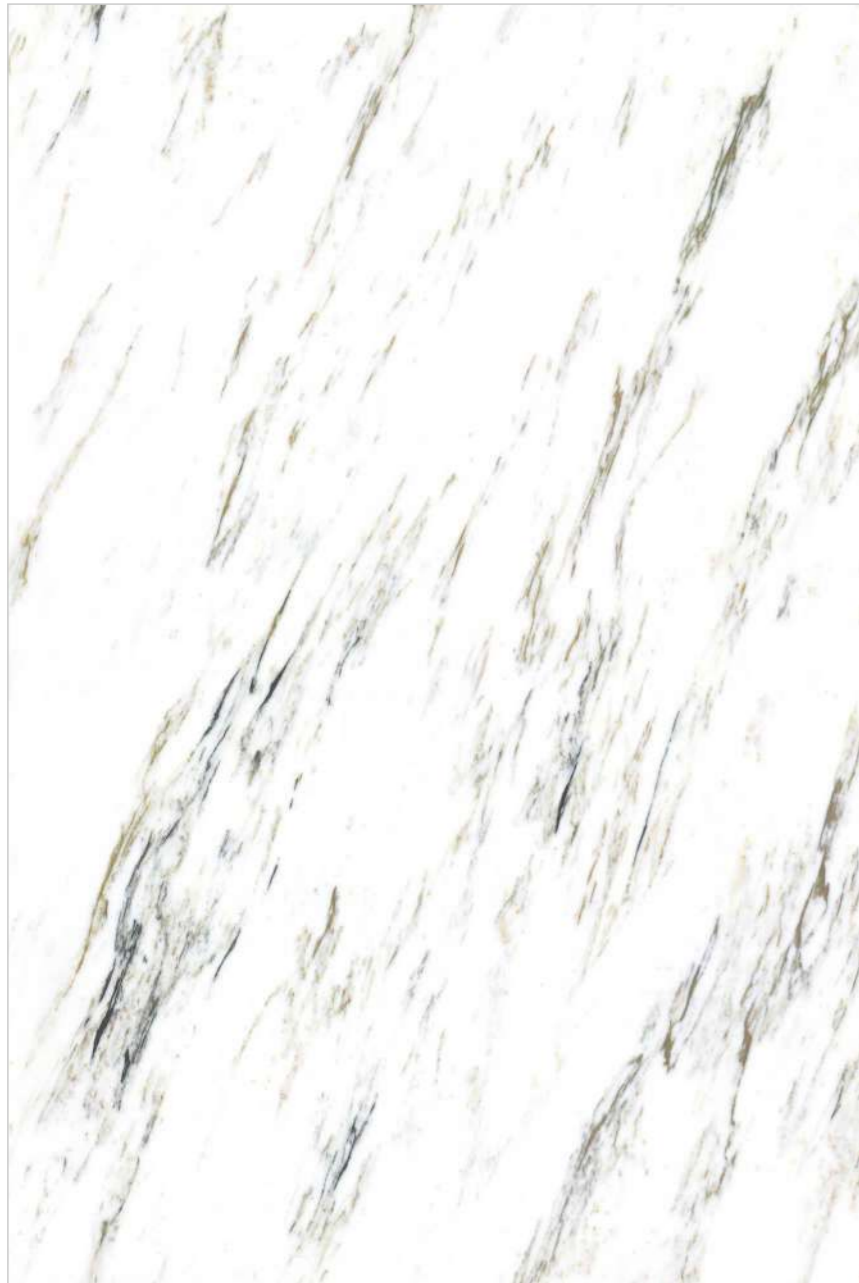



BELGIA WHITE
1200X1800MM | GLOSSY FINISH

1200X
1800MM | GLOSSY
SURFACE

BRECCIA SPRING - 3 RANDOMS

ENDLESS DESIGN



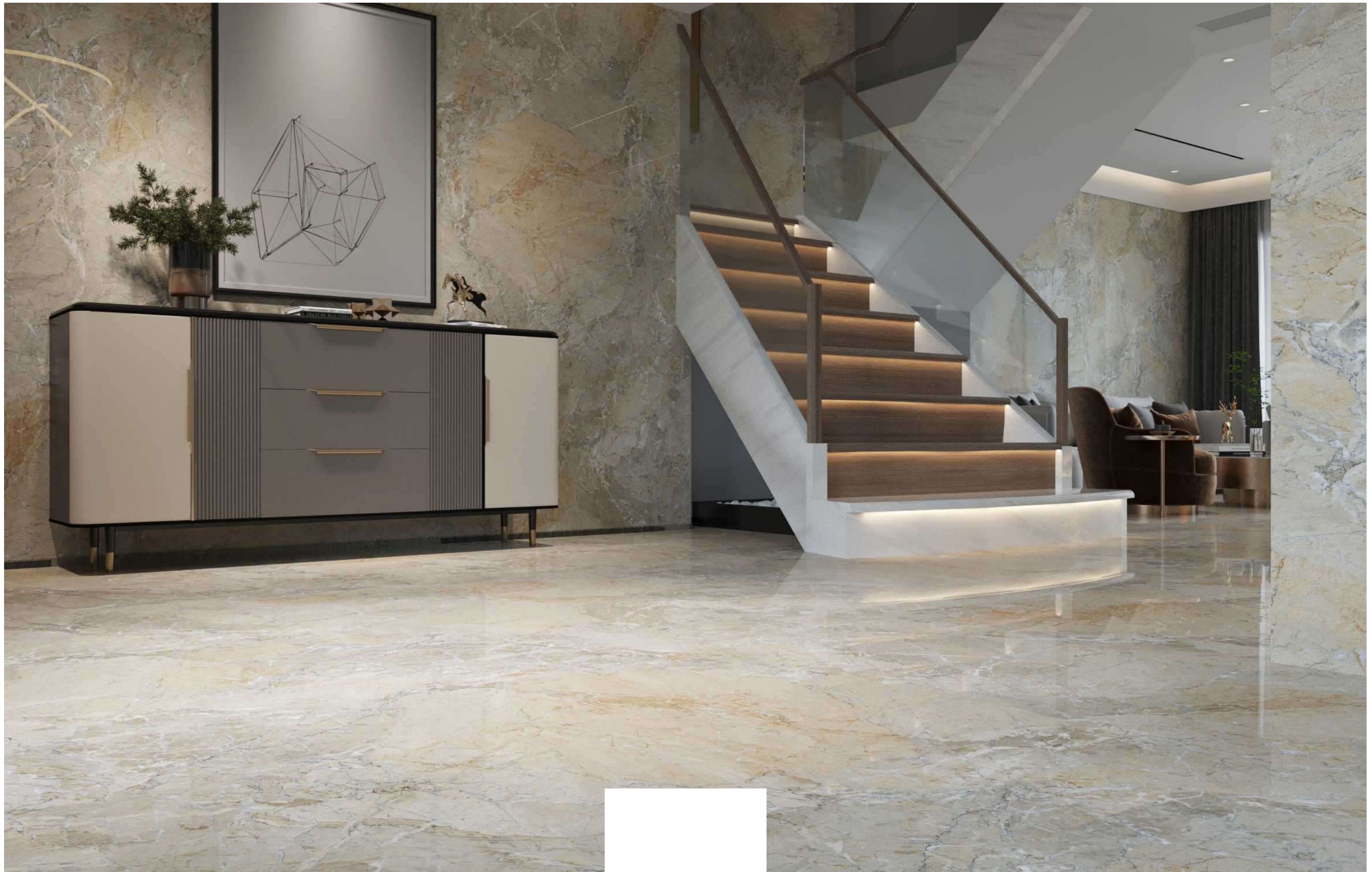

BRECCIA SPRING
1200X1800MM | GLOSSY FINISH

1200X
1800MM | GLOSSY
SURFACE

CALACATTA GLACIER - 3 RANDOMS





CALACATTA GLACIER
1200X1800MM | GLOSSY FINISH

1200X
1800MM | GLOSSY
SURFACE

CASA GREY - 3 RANDOMS

ENDLESS DESIGN



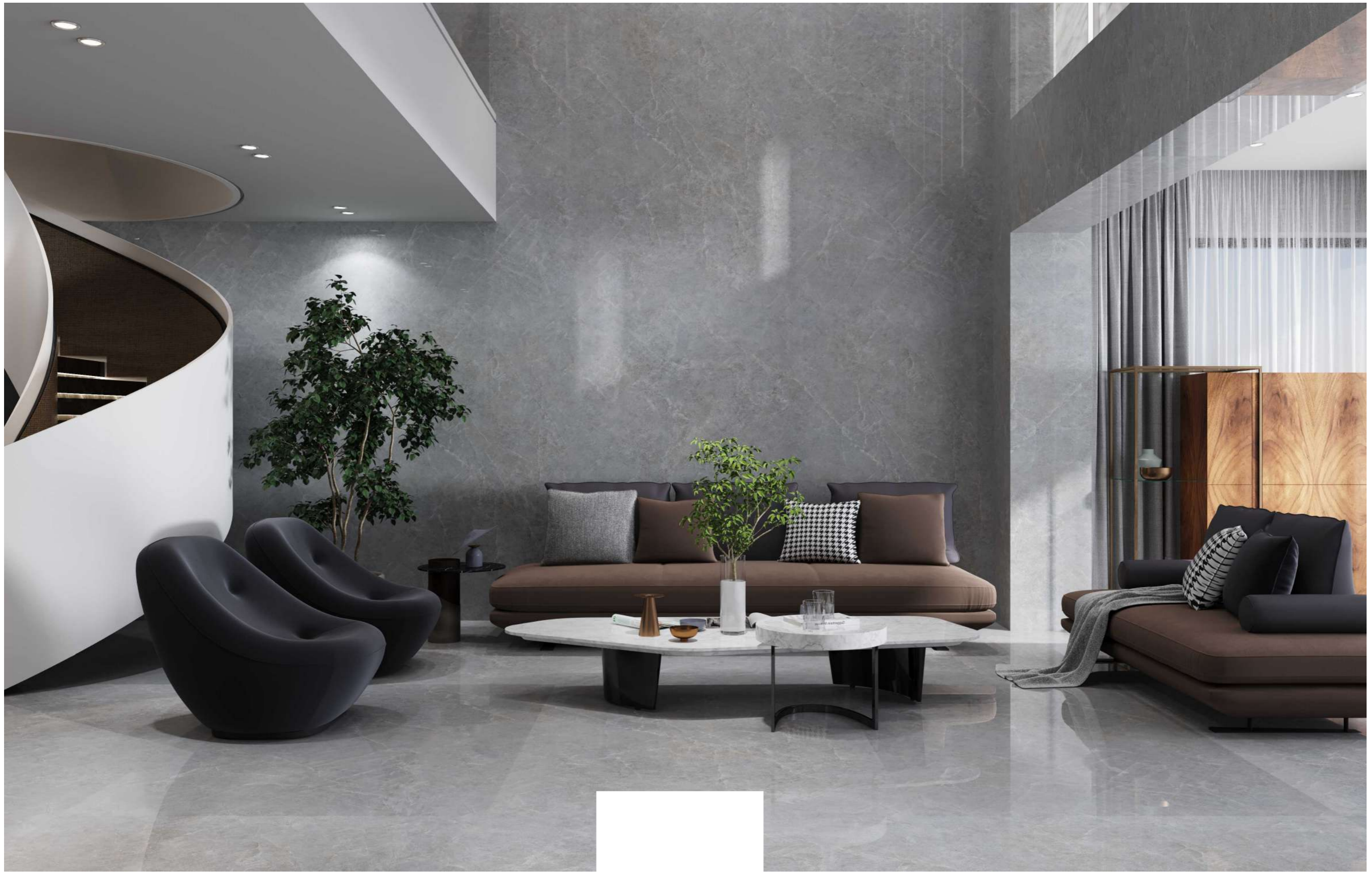

CASA GREY
1200X1800MM | GLOSSY FINISH

1200X
1800MM | GLOSSY
SURFACE

CASA - 3 RANDOMS

ENDLESS DESIGN

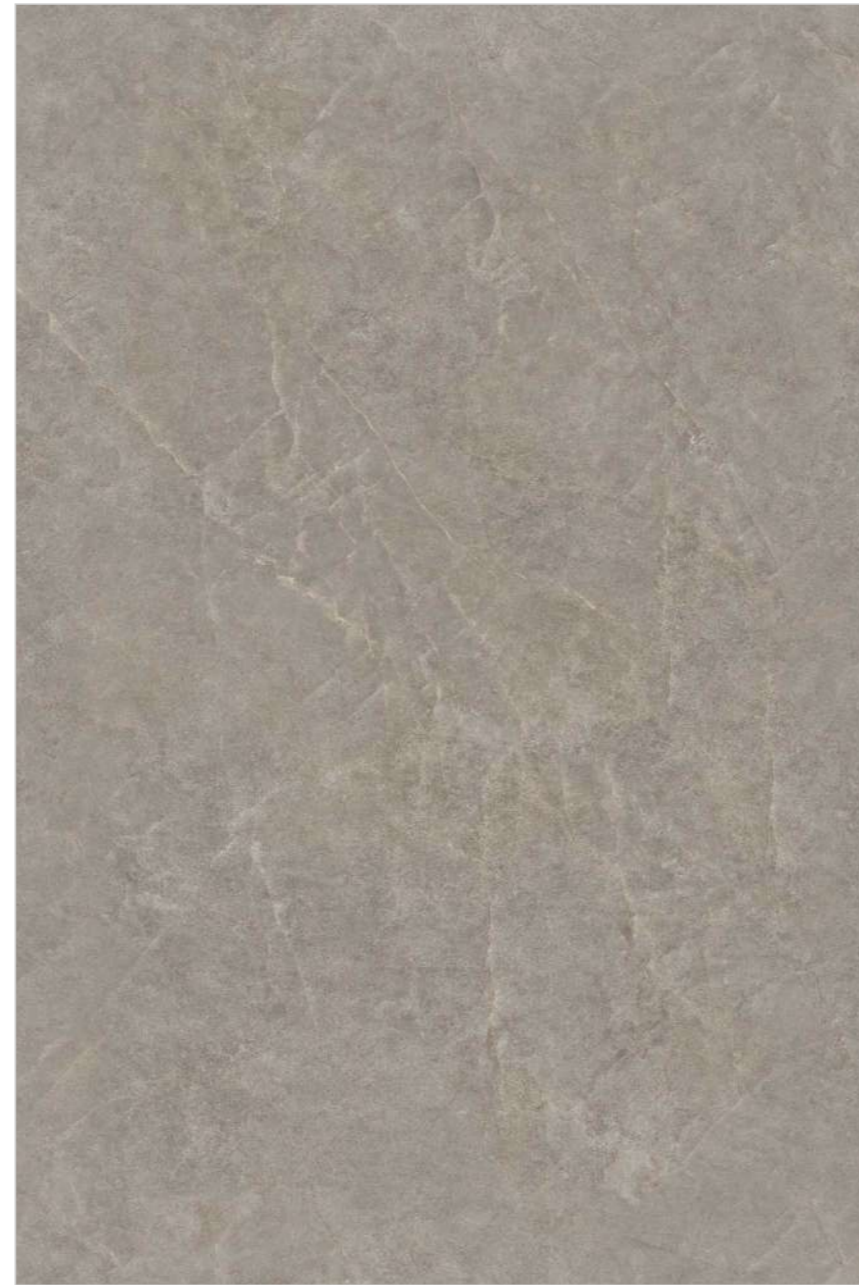



CASA
1200X1800MM | GLOSSY FINISH

1200X
1800MM | GLOSSY
SURFACE

DEKTON WHITE - 2 RANDOMS





DEKTON WHITE
1200X1800MM | GLOSSY FINISH

1200X
1800MM | GLOSSY
SURFACE

DURATO BEIGE - 3 RANDOMS





DURATO BEIGE
1200X1800MM | GLOSSY FINISH

1200X
1800MM | GLOSSY
SURFACE

EBRO NATURAL - 3 RANDOMS





EBRO NATURAL
1200X1800MM | GLOSSY FINISH

1200X
1800MM | GLOSSY
SURFACE

FUSION BEIGE - 3 RANDOMS





FUSION BEIGE
1200X1800MM | GLOSSY FINISH

1200X
1800MM | GLOSSY
SURFACE

FUSION BIANCO - 3 RANDOMS





FUSION BIANCO
1200X1800MM | GLOSSY FINISH

1200X
1800MM | GLOSSY
SURFACE

FUSION GRIS - 3 RANDOMS





FUSION GRIS
1200X1800MM | GLOSSY FINISH

1200X
1800MM | GLOSSY
SURFACE

GENOA BEIGE - 3 RANDOMS





GENOA BEIGE
1200X1800MM | GLOSSY FINISH

1200X
1800MM | GLOSSY
SURFACE

LEVIN GREY - 3 RANDOMS





LEVIN GREY
1200X1800MM | GLOSSY FINISH

1200X
1800MM | GLOSSY
SURFACE

LYON MOON - 3 RANDOMS

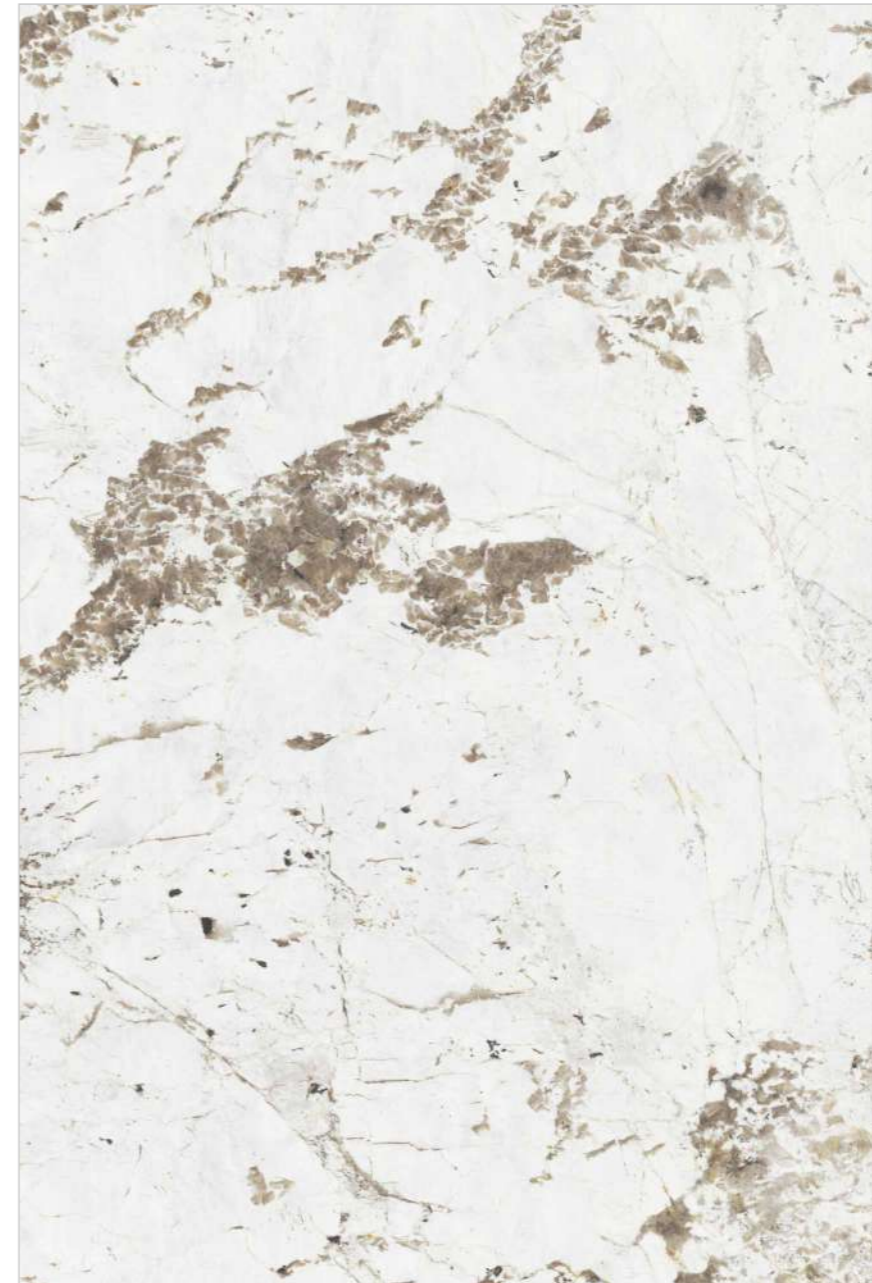



LYON MOON
1200X1800MM | GLOSSY FINISH

1200X
1800MM | GLOSSY
SURFACE

MACAEL WHITE - 3 RANDOMS





MACAEL WHITE
1200X1800MM | GLOSSY FINISH

1200X
1800MM | GLOSSY
SURFACE

MACUBA NATURAL - 3 RANDOMS





MACUBA NATURAL
1200X1800MM | GLOSSY FINISH

1200X
1800MM | GLOSSY
SURFACE

MERADIAN - 3 RANDOMS



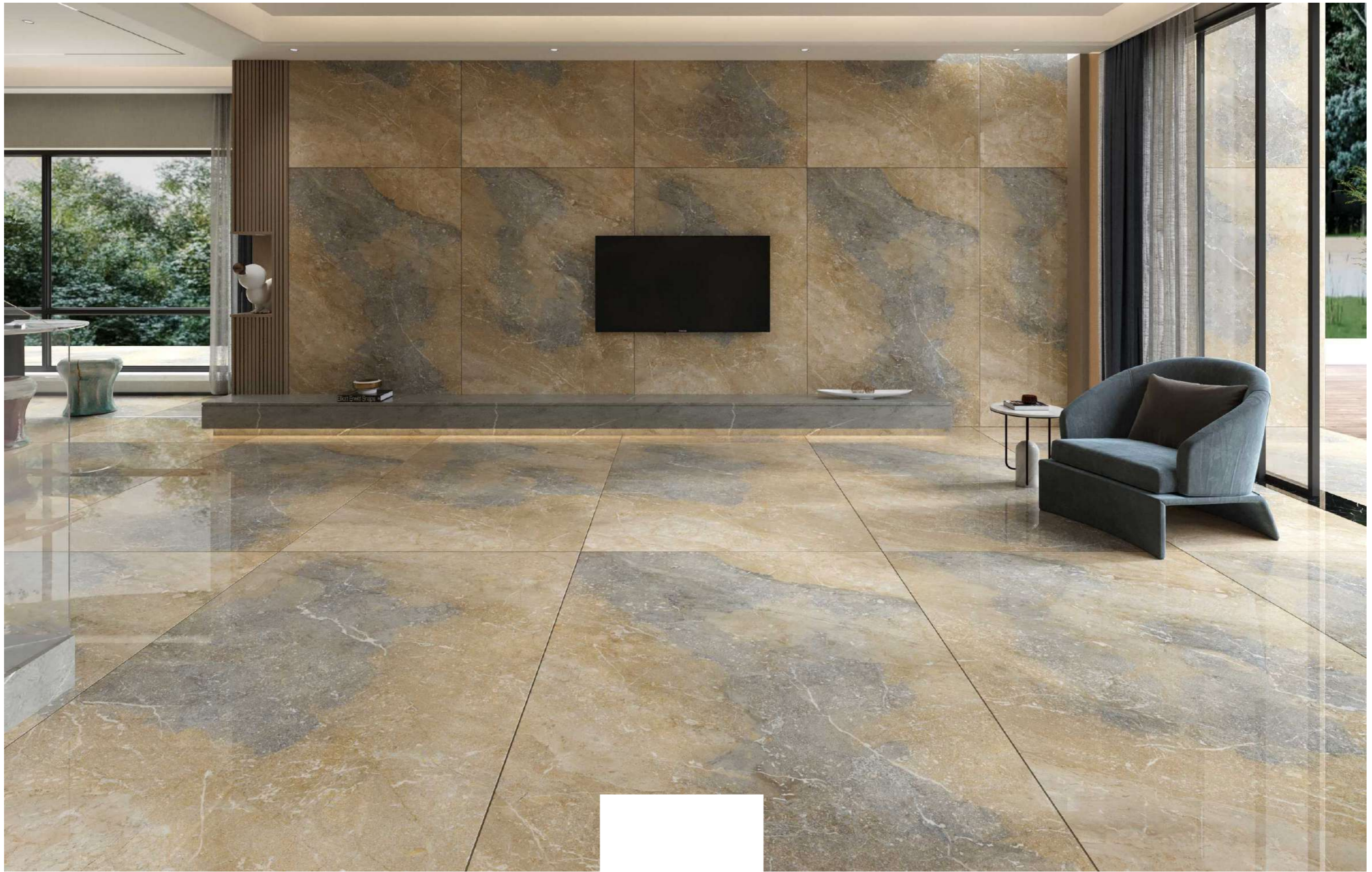

MERADIAN
1200X1800MM | GLOSSY FINISH

1200X
1800MM | GLOSSY
SURFACE

NUVOLA GREY - 2 RANDOMS





NUVOLA GREY
1200X1800MM | GLOSSY FINISH

1200X
1800MM | GLOSSY
SURFACE

ONYX SAFFRON - 3 RANDOMS





ONYX SAFFRON
1200X1800MM | GLOSSY FINISH

1200X
1800MM | GLOSSY
SURFACE

PARIS BEIGE - 3 RANDOMS

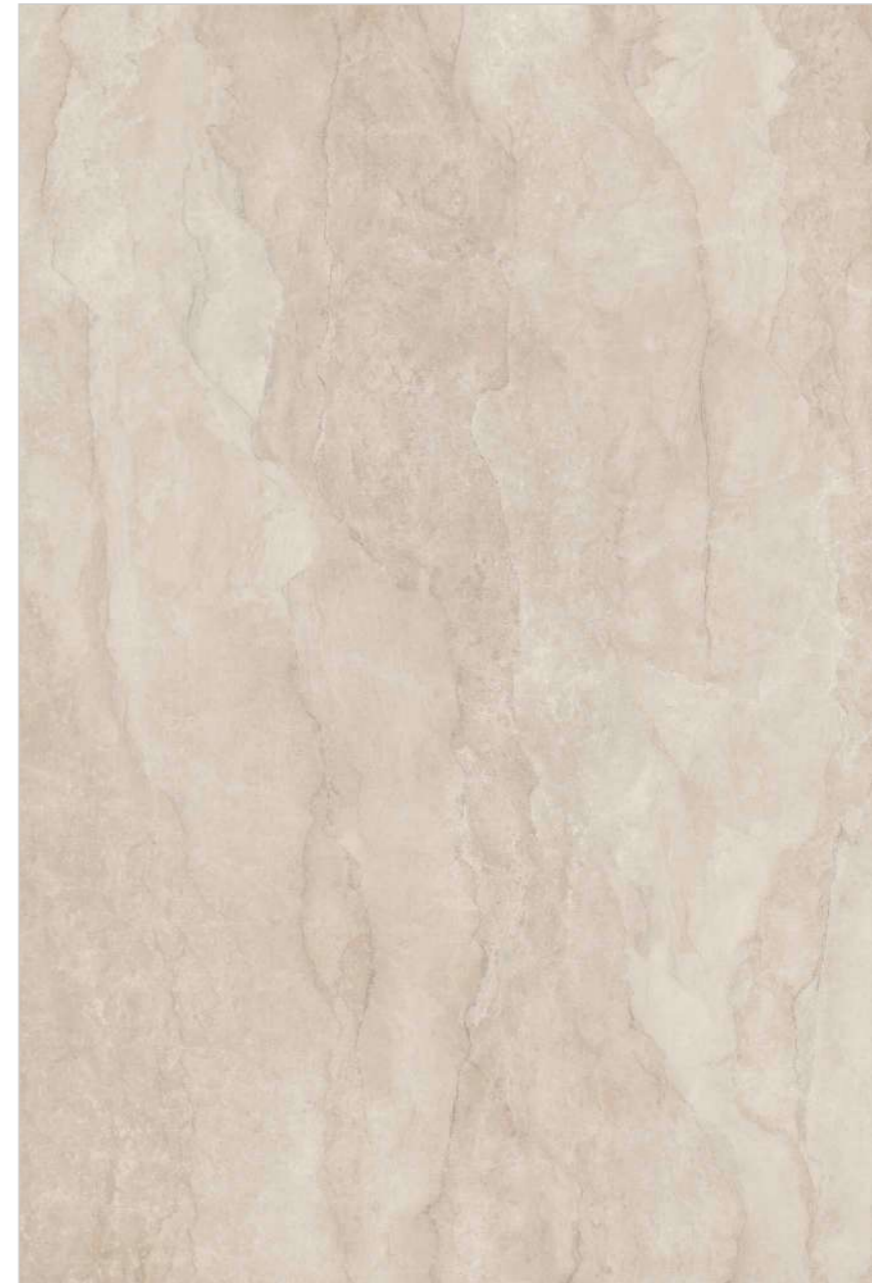

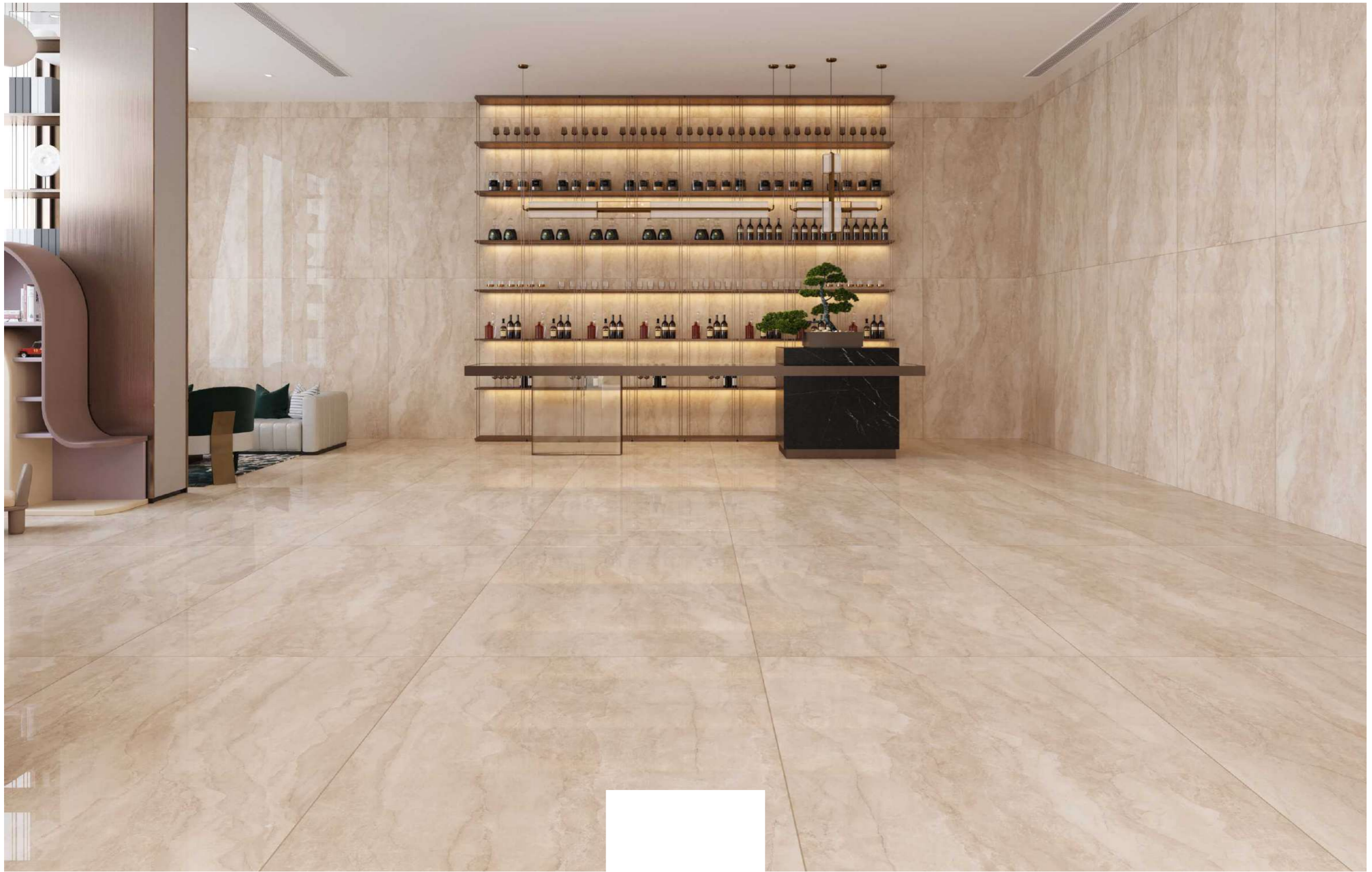

PARIS BEIGE
1200X1800MM | GLOSSY FINISH

1200X
1800MM | GLOSSY
SURFACE

RIVERA GREY - 3 RANDOMS





RIVERA GREY
1200X1800MM | GLOSSY FINISH

1200X
1800MM | GLOSSY
SURFACE

ROYAL STATUARIO - 3 RANDOMS

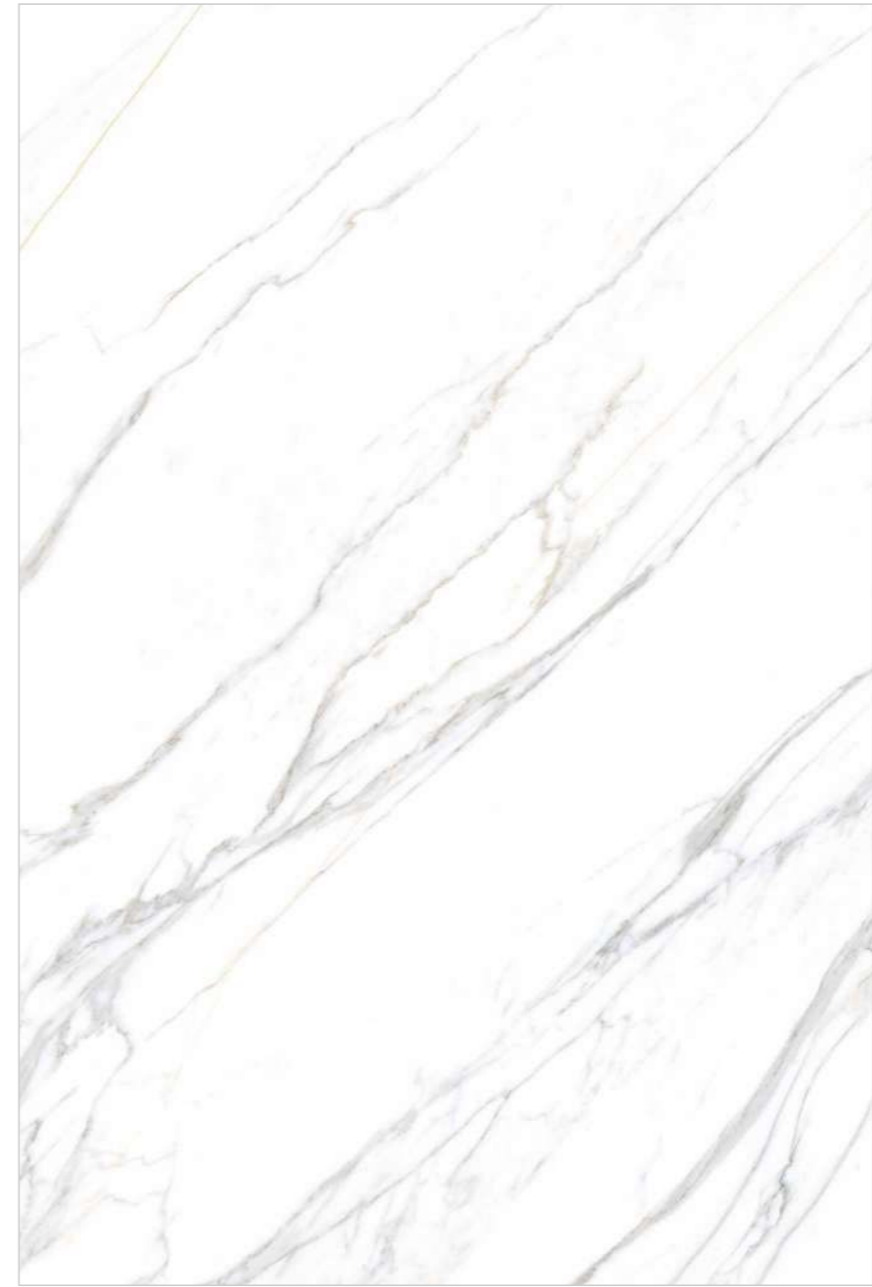
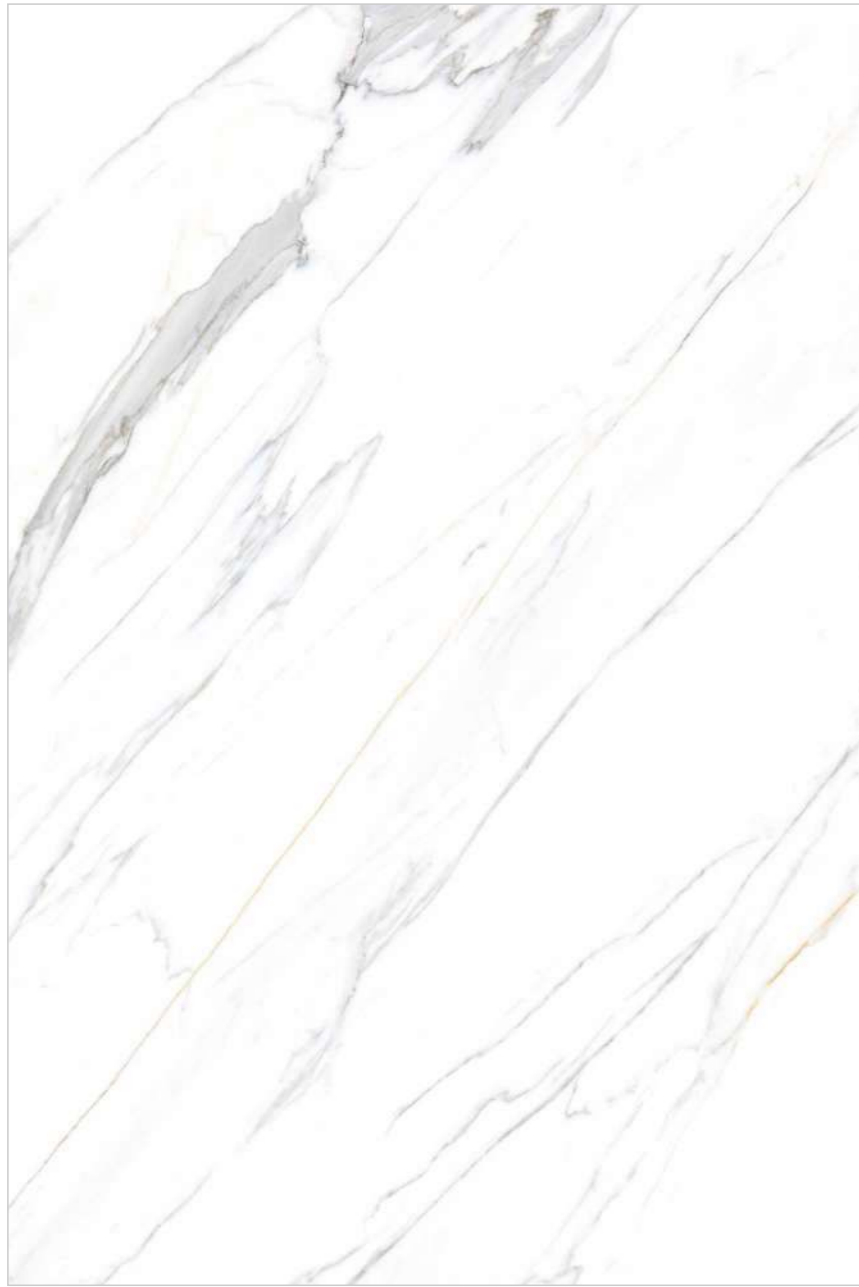

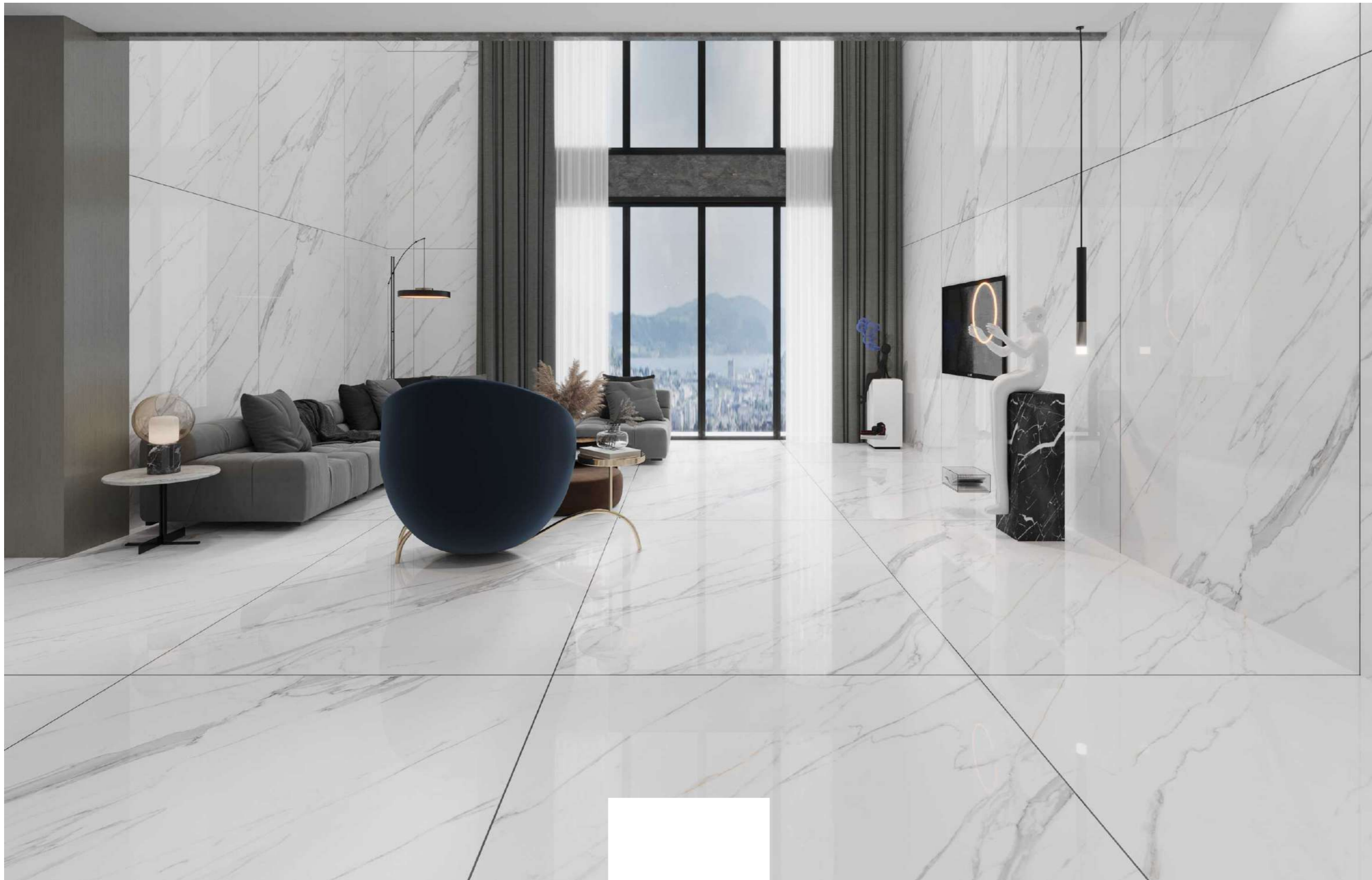

ROYAL STATUARIO
1200X1800MM | GLOSSY FINISH

1200X
1800MM | GLOSSY
SURFACE

SARRON COLIN - 3 RANDOMS



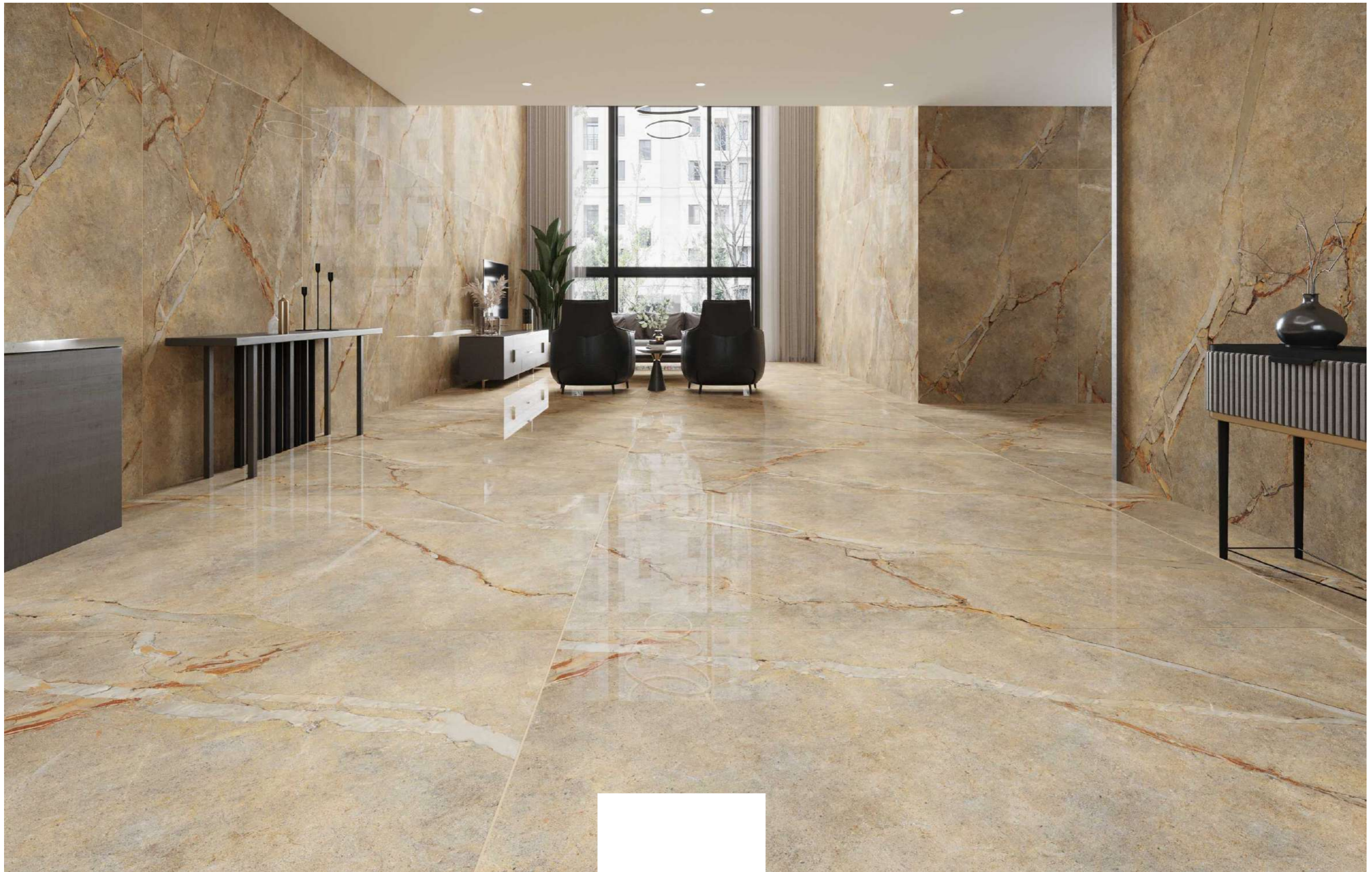

SARRON COLIN
1200X1800MM | GLOSSY FINISH

1200X
1800MM | GLOSSY
SURFACE

SATURN BROWN - 3 RANDOMS





SATURN BROWN
1200X1800MM | GLOSSY FINISH

1200X
1800MM | GLOSSY
SURFACE

SYBER ASH - 4 RANDOMS

ENDLESS DESIGN





SYBER ASH
1200X1800MM | GLOSSY FINISH

1200X
1800MM | GLOSSY
SURFACE

SYBER GREY - 4 RANDOMS

ENDLESS DESIGN



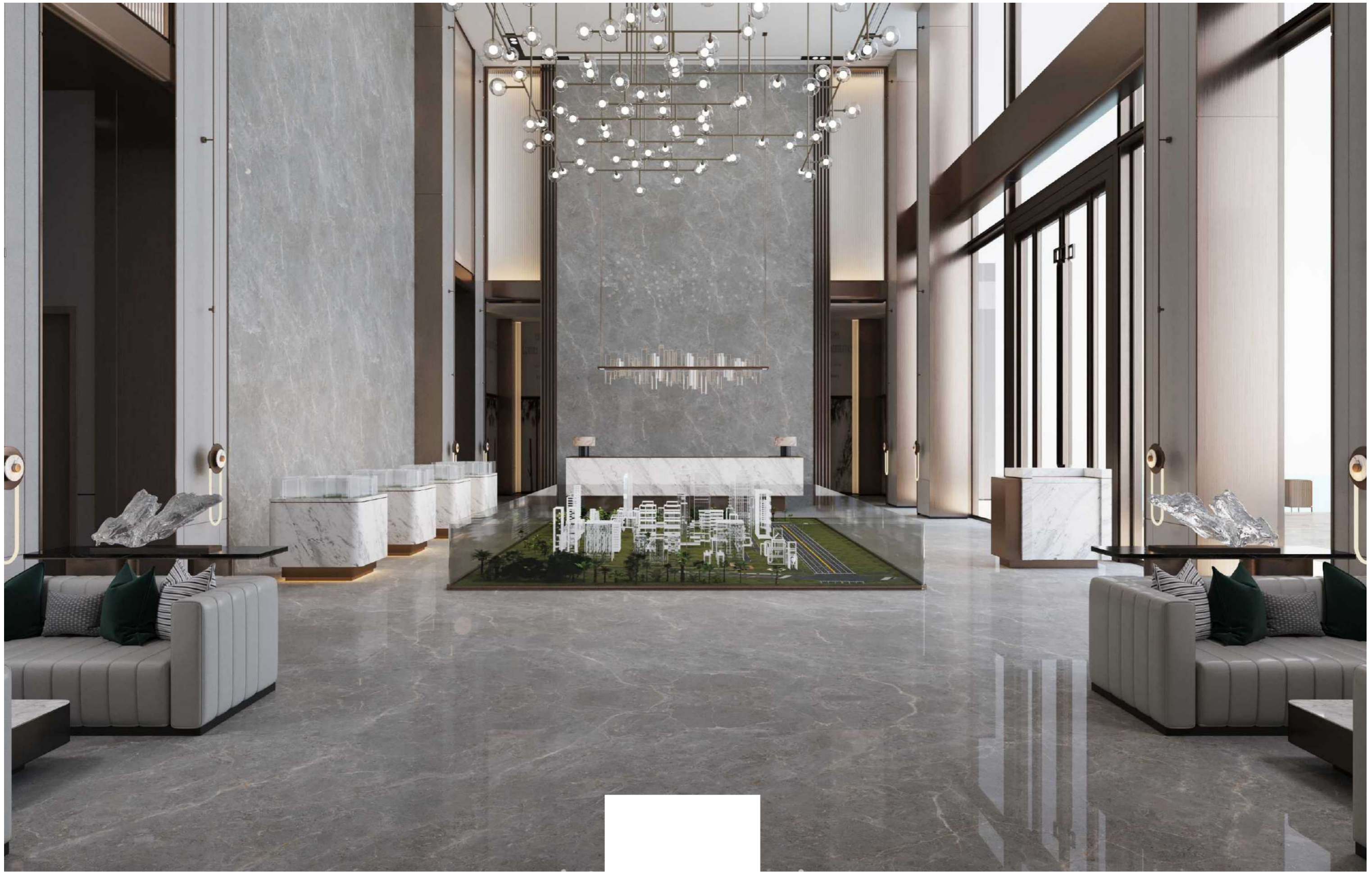

SYBER GREY
1200X1800MM | GLOSSY FINISH

1200X
1800MM | GLOSSY
SURFACE

VEGAS BEIGE - 3 RANDOMS

ENDLESS DESIGN





VEGAS BEIGE
1200X1800MM | GLOSSY FINISH

General Indication For Handling, Cutting And Laying

Handling

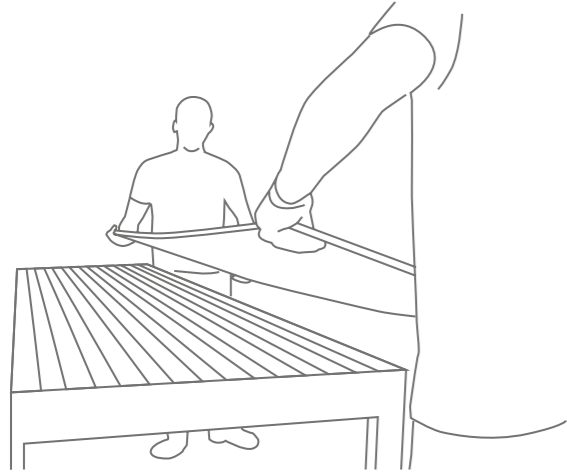

Where possible, mechanical lifting systems should be used for delivering slabs above the ground floor.

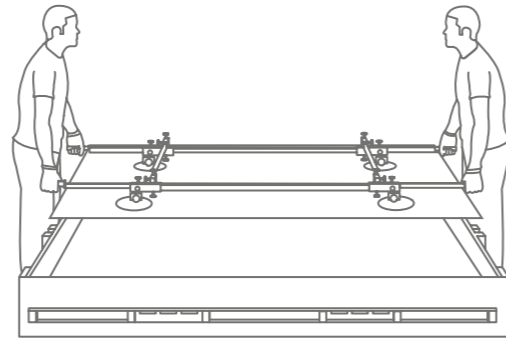

Handling the slabs on the floor can be managed with the aid of a frame fitted with suction cups to make the slabs more stable.

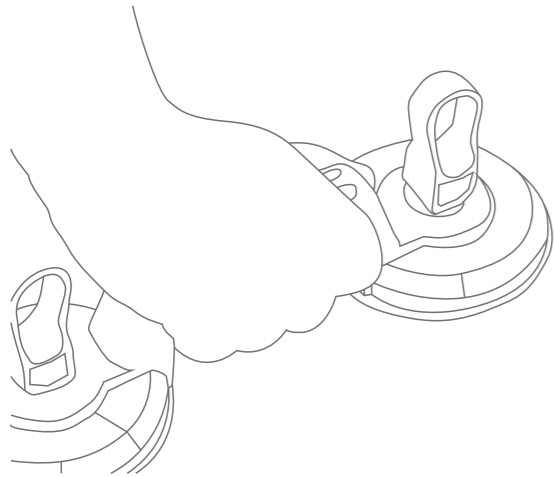

The appropriate suction cups may be used for manual handling.

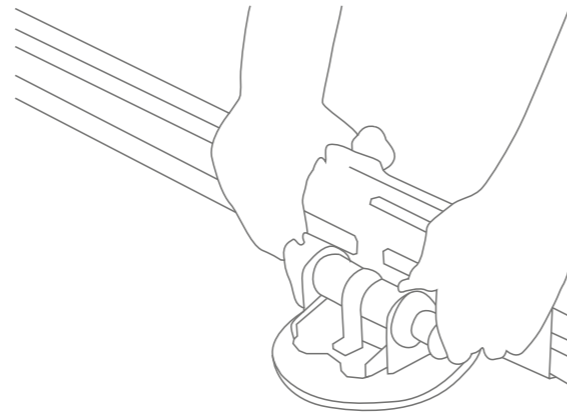

To facilitate handling of slabs with textured surfaces, the appropriate suction cups should be used.

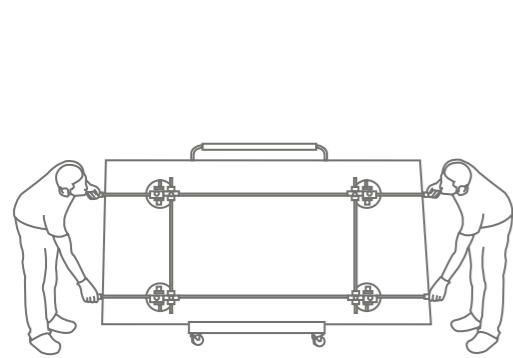

For moving the slabs over large surfaces, a forklift can be used.

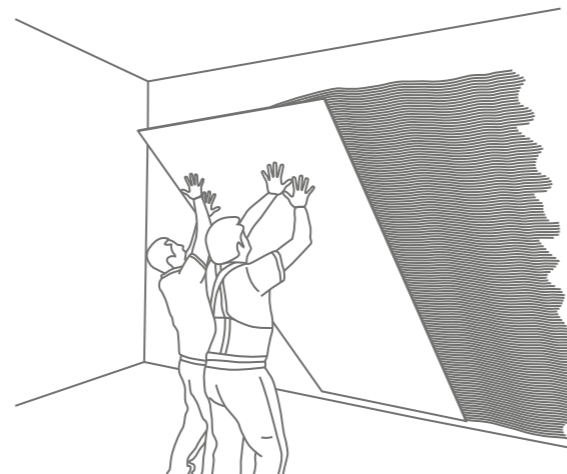

Once the slab is in position, excess air should be removed completely by tapping it either manually or mechanically using the appropriate trowel, starting from the centre and moving out towards the sides.

Cutting

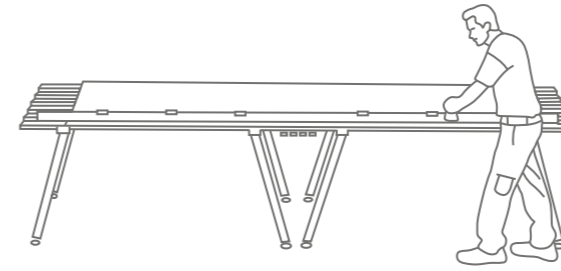

Cutting operations should be carried out on a perfectly stable, flat surface.

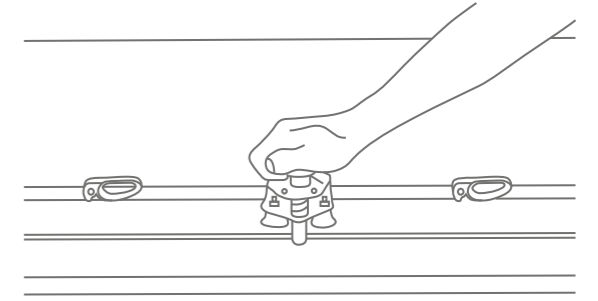

A cutting guide fitted with a diamond tip tool is recommended.

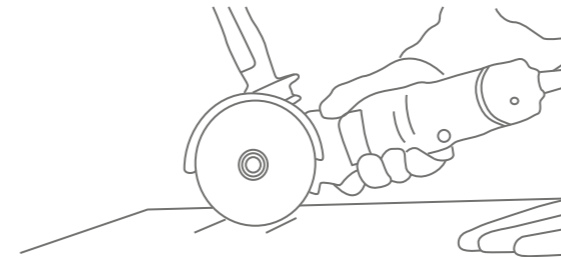

To cut the slab without breaking the material, the appropriate shears should be used.



The slabs can also be cut with a dry saw or wet saw with a diamond wheel cutter.

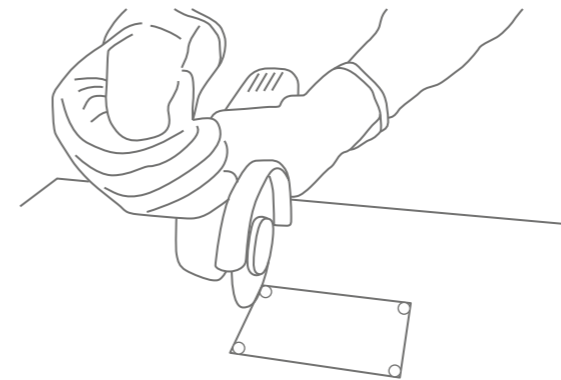

For L-shaped cuts or cuts inside the slab, holes should be bored at the vertices to prevent the blade of the cutting disk damaging the surface.

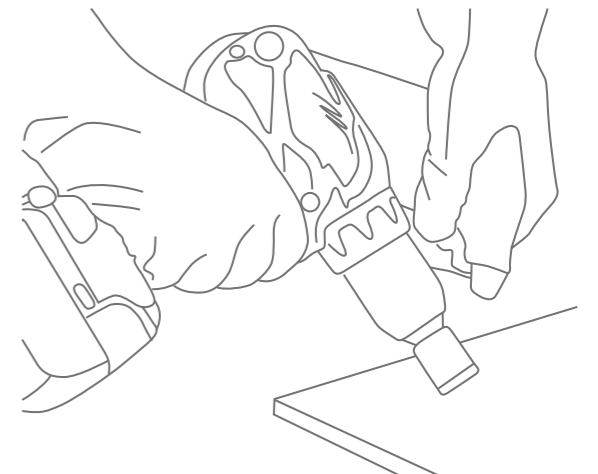

To bore cylindrical holes on the slabs, a diamond cutting tool of the desired diameter should be used, and the surface should be kept wet constantly.

TECHNICAL SPECIFICATION

TEST DESCRIPTION	TEST METHOD	ISO STANDARD 13006 B1a TILES	VALUE
Length and width	BS EN ISO 10545-2	± 0.6%	± 0.3%
Thickness	BS EN ISO 10545-2	± 5.0%	± 3.0%
Straightness of sides	BS EN ISO 10545-2	± 0.5%	± 0.3%
Rectangularity	BS EN ISO 10545-2	± 0.6%	± 0.3%
Surface flatness	BS EN ISO 10545-2	± 0.5%	± 0.3%
Water absorption	BS EN ISO 10545-3	≤ 0.5%	≤ 0.05%
Breaking strength	BS EN ISO 10545-4	≥ 1300N	≥ 1500N
Modulus of rupture	BS EN ISO 10545-4	≥ 35 N/mm ²	≥ 45N/mm ²
Resistance to deep abrasion	BS EN ISO 10545-6	≤ 175mm ³	≤ 150mm ³
Linear thermal expansion	BS EN ISO 10545-8	≤ 9 x 10 ⁻⁸ °C ⁻¹	≤ 7 x 10 ⁻⁶ °C ⁻¹
Thermal shock resistance	BS EN ISO 10545-9	No visible defect	No visible defect
Frost resistance	BS EN ISO 10545-12	Frost proof	Frost proof
Resistance to chemicals	BS EN ISO 10545-13	No visible effect	No visible effect
Resistance to stain	BS EN ISO 10545-14	Manufacturer to state class	Stains removed Min. Class 2
Colour resistance	BS EN ISO 10545-16	No damage	No damage
Colour resistance to UV Light	DIN 51094	No change in color	No change in color
Scratch hardness(MOH's Scale)	EN 101	≥ 6 MOHS	≥ 7 MOHS
Surface quality	BS EN ISO 10545-2	Min. 95%	No visible defect
Skid resistance (friction co-efficient)	BS EN ISO 10545-17	> 0.4	>0.4
Moisture Expansion	-	Nil	Nil



10⁺

Year Of Experience

200⁺

Unique Designs

40⁺

Export Countries

PACKING DEATILS

Size	Pcs / Box	Weight (Approx)	Thickness (Approx)	SQ. / Box
1200x1800	2	90 kg	9mm	46.50

Thank You